

INVESTOR RELATIONS PRESENTATION

APRIL 2026



AGENDA

- 1. Key Facts about Einhell**
- 2. Financial Figures**
- 3. Our Way to the 2nd Billion EUR**
- 4. Einhell Share**
- 5. Summary**

1. KEY FACTS ABOUT EINHELL



1. KEY FACTS ABOUT EINHELL

Who we are and what we do

- Einhell is a leading manufacturer and distributor of power tools and gardening equipment.
- Einhell provides the battery power platform for the DIY and professional world.
- With one battery for more than 350 tools, Power X-Change ensures cordless freedom and complete flexibility.
- Einhell stands for maximum cordless excellence in the home, garden and leisure sectors.
- The constantly growing ecosystem, powerful products and visionary ideas make Einhell a pioneer in the field of battery technology for all DIY enthusiasts and professionals.
- Based in Landau/Isar (Bavaria)
- Founding year 1964
- Employees worldwide: ~ 2.600
- Subsidiaries: 51



2. FINANCIAL FIGURES



Einhell 35CM
PROFESSIONAL 14"
ORIGON
CHAINSAW

2. DEVELOPMENT OF KEY FINANCIALS 2025

SALES

+ 48 mio. €

+ 4,3 %

FX adjusted sales growth is 8,0 %
main impact from AUS, but also
TUR, ARG and CAN

CAGR
11,4 %

1.157,7

1.109,7

1.032,5

927,4

971,5

724,7

605,7

2019

2020

2021

2022

2023

2024

2025

Group Sales in million Euro

EBT

+ 9,4 mio. €

+ 9,5 %

CAGR
22,1%

107,9
(9,3%)

98,5
(8,9%)

75,4
(7,8%)

87,4
(8,5%)

81,8
(8,8%)

56,4
(7,8%)

32,5
(5,4)

2019

2020

2021

2022

2023

2024

2025

Group EBT in million Euro

SALES CHANNELS DEVELOPMENT

Sales Channels – TOTAL

*decline in TT, mainly driven by FX impact

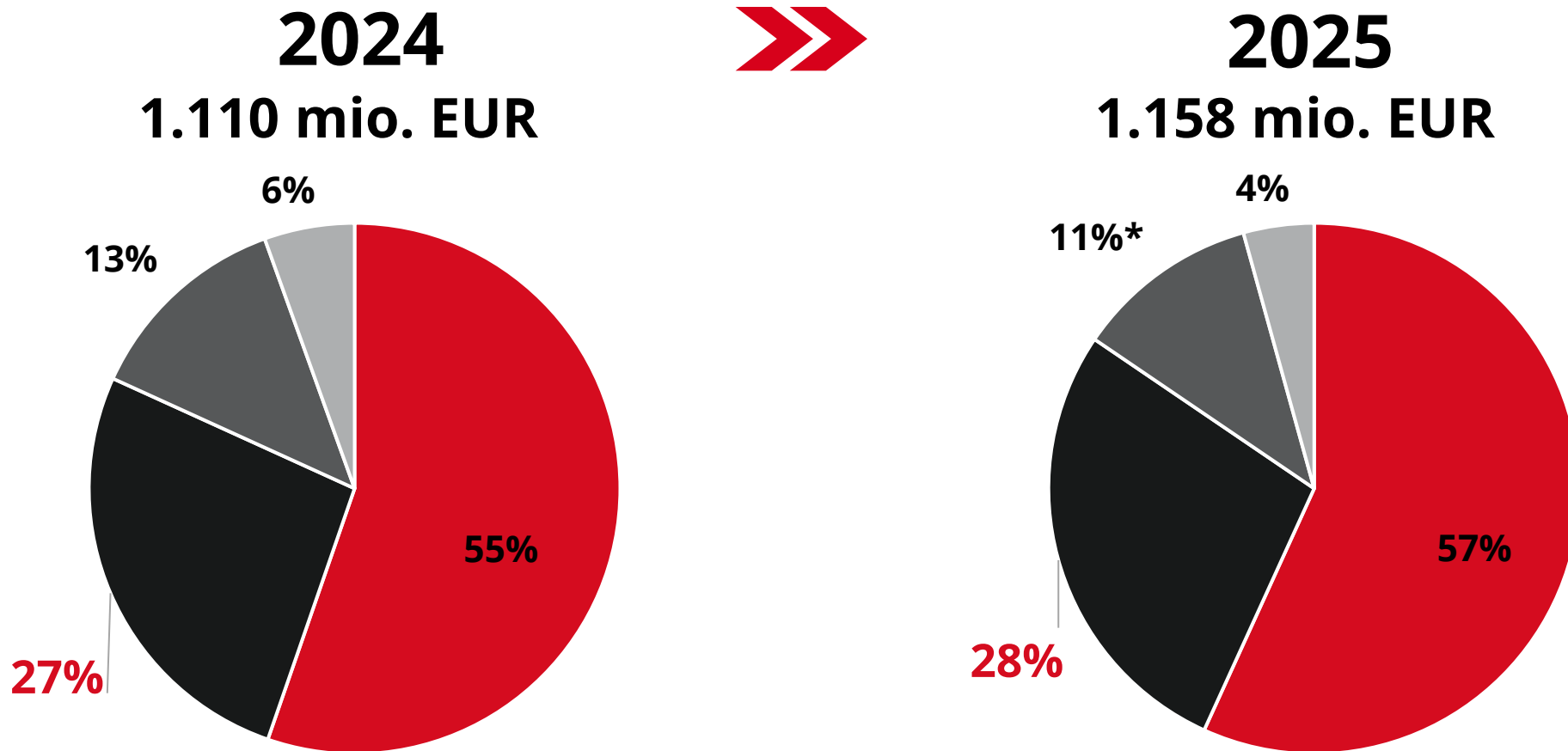

DIY

E-Commerce

Traditional Trade

Others

2. DEVELOPMENT OF KEY FINANCIALS 2026

SALES OUTLOOK

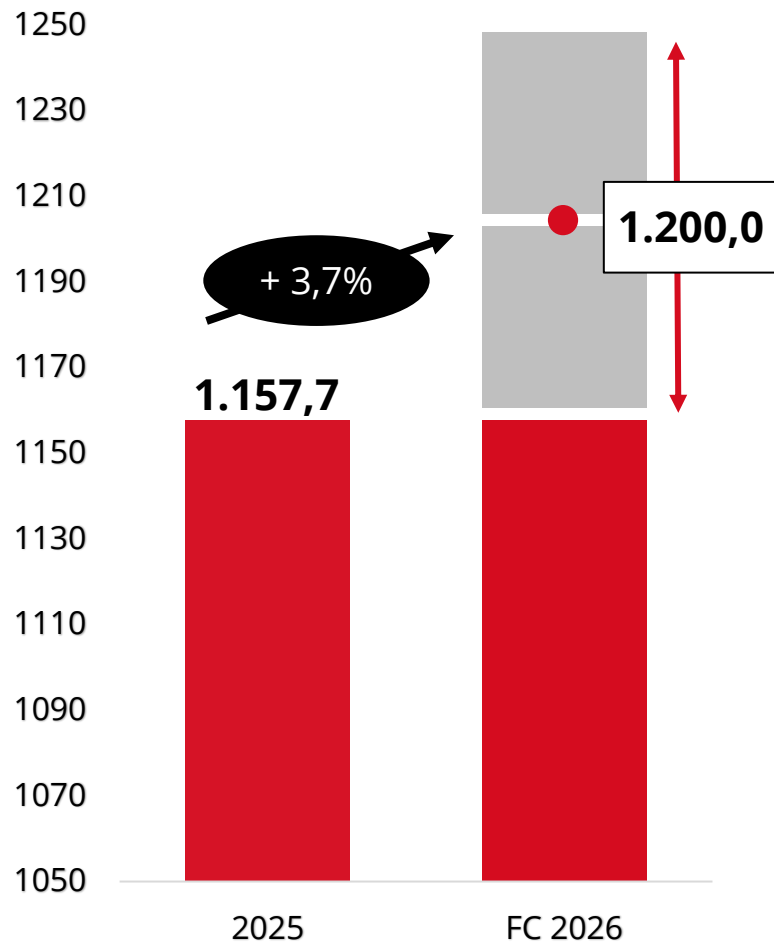

EBT OUTLOOK

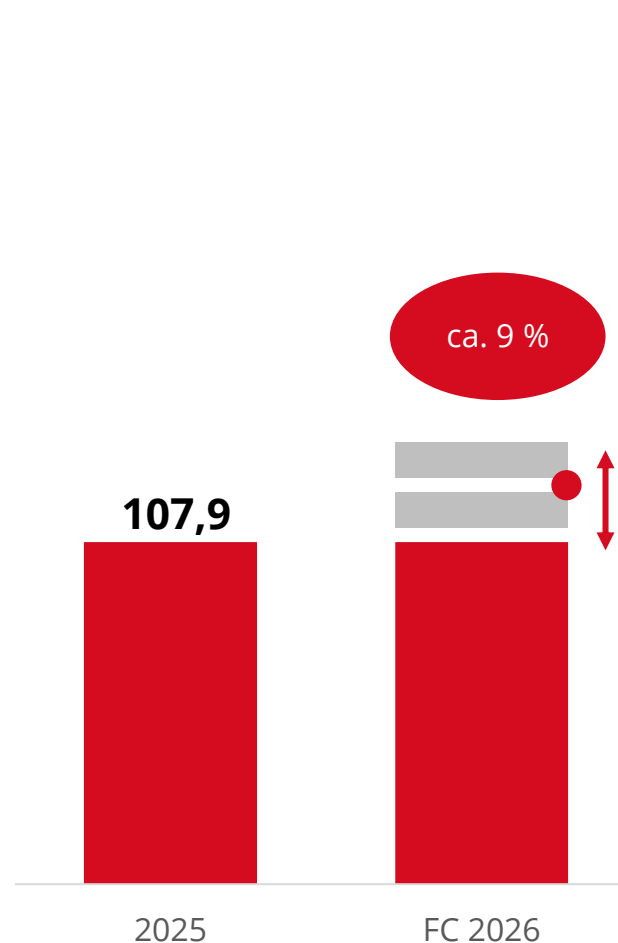

COMMENTS

Assumptions and Environment

Overall uncertainty due to geopolitical development

No further decline in customer sentiment and purchasing power

Dependency on customer demand in gardening season

Sales Growth

Organic growth, no acquisitions included

Major impact from new listings at international DIY chains and assortment extension (Professional + Recreation)

EBT Growth

Further increase of gross margin (PXC/product mix) and safeguarding main influences (raw materials, FX, sea freight)

Focus on overall cost controlling

2. Financial Figures

Current Situation in 2026 - Turnover per **31.03.2026**

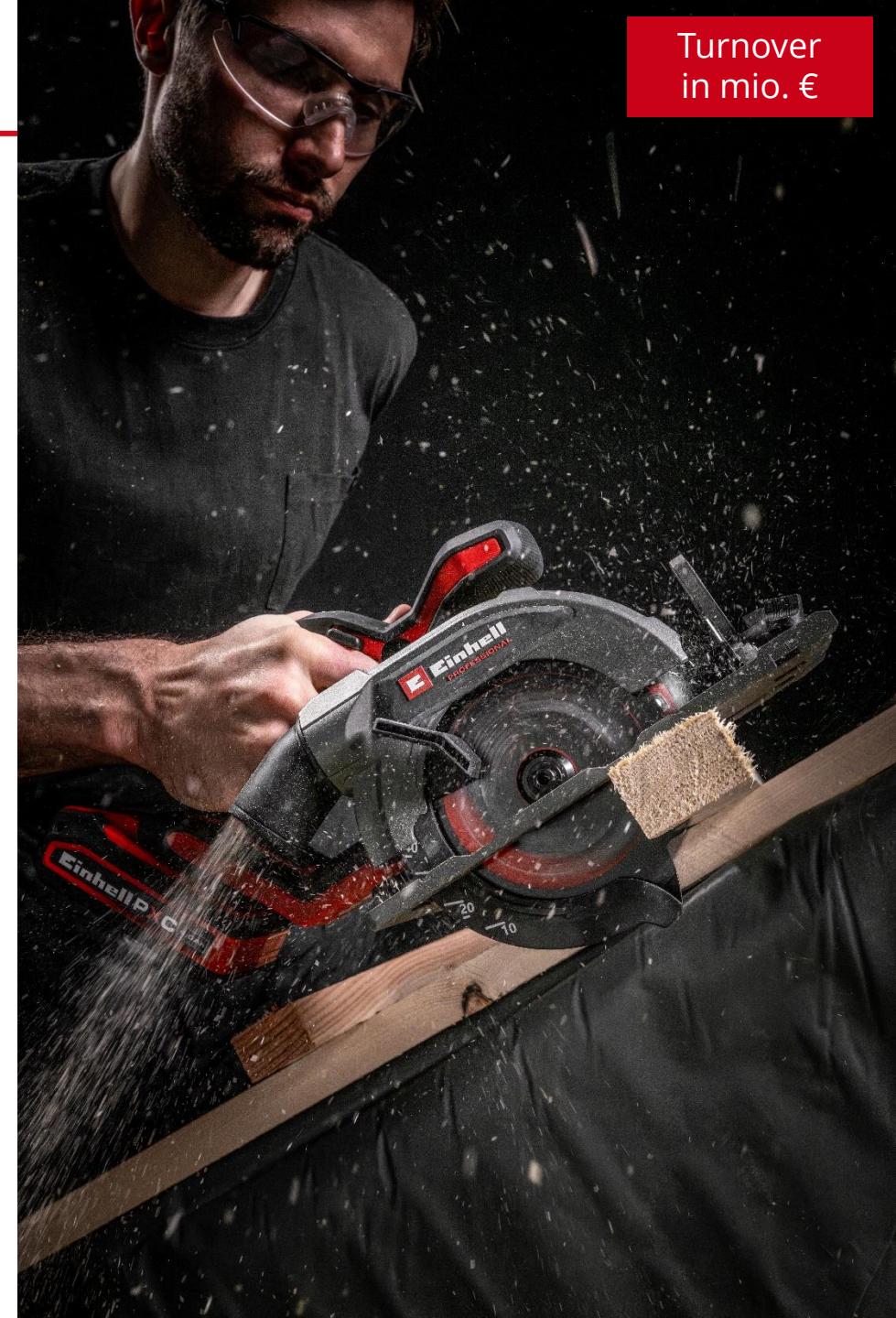
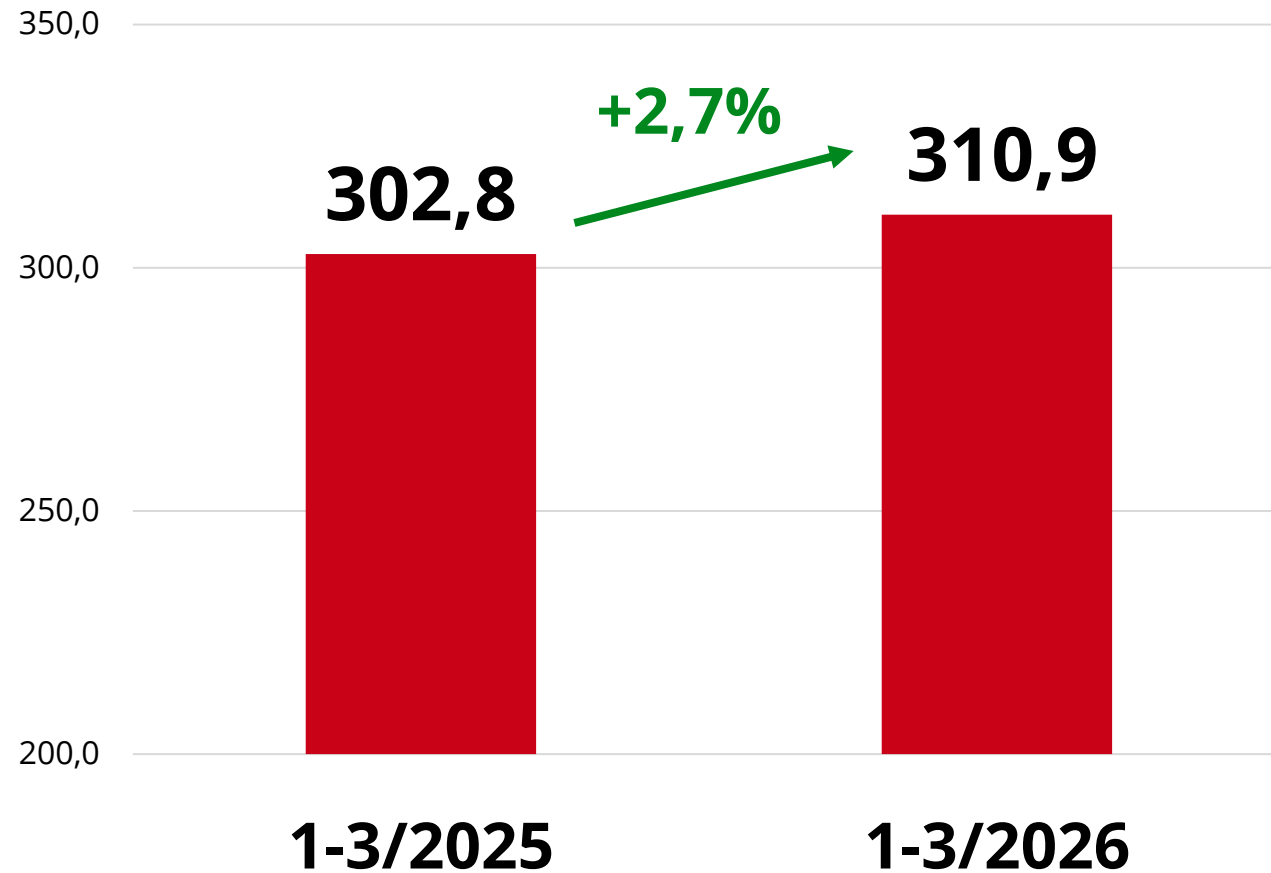

Turnover
in mio. €

3. OUR WAY TO THE 2ND BILLION



3. OUR WAY TO THE 2ND BILLION

VISION

One Power X-Change (PXC) battery in each household, garden and workshop

MISSION

We offer our customers cordless freedom for all jobs in and around their home, garden and workshop - wherever they want to be mobile and free. With the most competent battery platform called POWER X-CHANGE, we help millions of customers worldwide to enjoy completing their projects with CORDLESS EXCELLENCE - maximum flexibility, seamless compatibility, truly sustainable.

STRATEGIC KEY TARGETS ARE ...

**DISTRIBUTION
EXPANSION**

**BRAND
BUILDING**

**CORDLESS
EXCELLENCE**

**EINHELL
PROFESSIONAL**

**EINHELL
ACCESSORY**

3. OUR WAY TO THE 2ND BILLION

CORDLESS EXCELLENCE



3. OUR WAY TO THE 2ND BILLION

POWER XCHANGE

Market Leadership with Power X-Change

» Positioning Einhell as the **Cordless Excellence** and becoming market leader with **Power X-Change in all countries** with an own subsidiary.



3. OUR WAY TO THE 2ND BILLION

POWER X CHANGE

Platform Competence with Power X-Change

- With **Power X-Change** we offer the **broadest and most competent battery platform** for home, garden and workshop!
- Within this platform, it is very important that we **offer a solution for every task in home, garden and workshop** where the customer needs and wants **cordless freedom**.

2025



350+ SKUs

2029+



500+ SKUs

SEALED
TECHNOLOGY

POWER X CHANGE



3Ah + 4Ah SEALED
POWER X-CHANGE PLUS BATTERY

SEALED
TECHNOLOGY

POWER X CHANGE

4Ah TABLESS

40% more power



*This battery enables
higher performance and faster,
better work when used with the same tools!*

3. OUR WAY TO THE 2ND BILLION

Share of Power X-Change Assortment

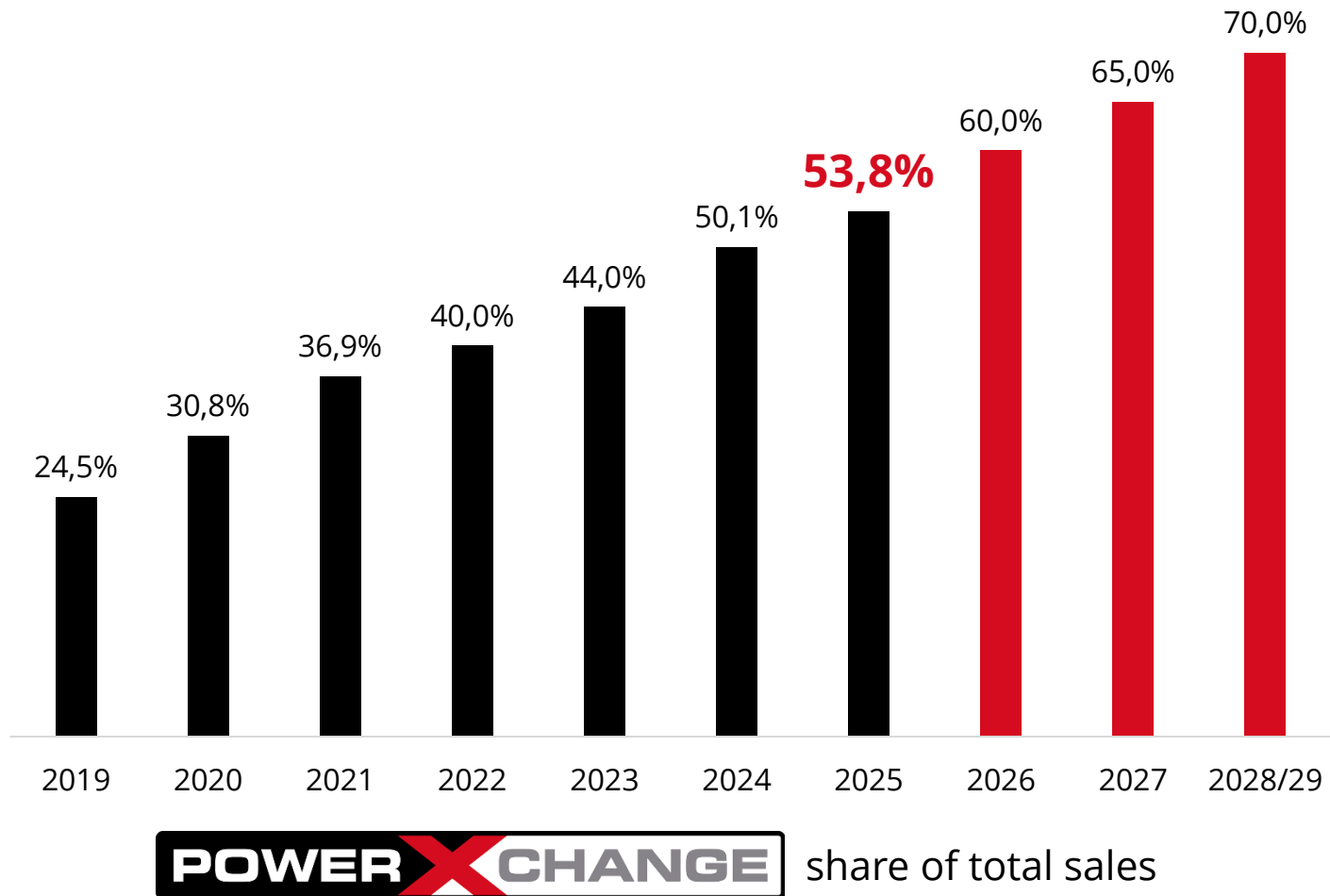

3. OUR WAY TO THE 2ND BILLION



Sold Power X-Change Batteries

POWER X CHANGE
UNSER GEMEINSAMES ZIEL
78 MIO
PKC AKKUS
BIS 2029

weltweit verkaufte PXC Akkus
44.102.802
1460 : 23 : 59 : 59
Tage Stunden Minuten Sekunden

57%

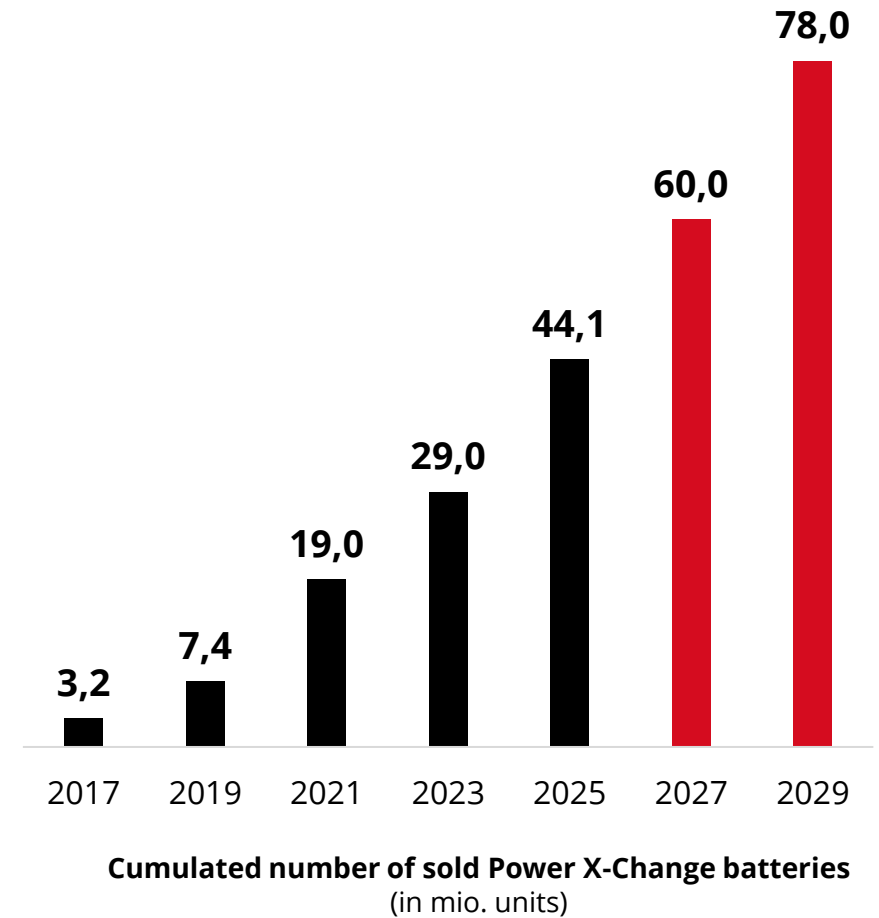

3. OUR WAY TO THE 2ND BILLION

EINHELL PROFESSIONAL



 **Einhell**
PROFESSIONAL

3. OUR WAY TO THE 2ND BILLION

Einhell PROFESSIONAL – Target Groups

Remodeler



Floor Installer



Electrician



PV Installer



Landscaper



Facility Manager



Carpenter



Painter



Smart Home Tech



Gardener



Farmer



Car Mechanic



3. OUR WAY TO THE 2ND BILLION

Einhell PROFESSIONAL – Quality & Benchmarks

- ▶ We benchmark all our Einhell PROFESSIONAL products with top A-brands in terms of function and handling. The benchmarks are done by SLG without any exception.
- ▶ Since 2025: we also benchmark Einhell PROFESSIONAL products in terms of endurance with the aim to achieve the same result.



PERFORMANCE

= 100%

HANDLING

= 100%

DURABILITY

= 80%

Target
step by step
100%

3. OUR WAY TO THE 2ND BILLION

Einhell PROFESSIONAL – Design

TP-AG 36/230 Li BL



AXXIO 36/230 Q



3. OUR WAY TO THE 2ND BILLION

3.4 Einhell PROFESSIONAL – Product Range until end of 2026

Expansion of the **PROFESSIONAL** range to **128 products** until end of 2026



End of 2025

End of 2026

End of 2025

End of 2026

71 SKUs

88 SKUs

32 SKUs

40 SKUs

17 new products to come

8 new products to come

COMPACT SERIES



- 1 **MORE COMPACT**
- 2 **MORE POWER**
- 3 **MORE FEATURES**

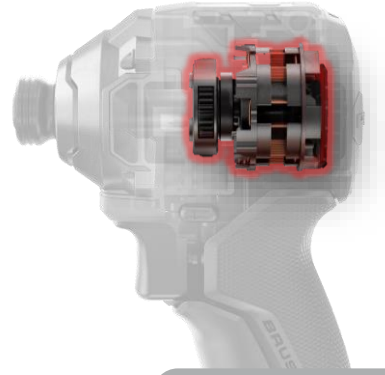

1 **MORE COMPACT**

TP-HD 18/17-C Li BL vs. TE-HD 18/20 Li

- 30% SHORTER
- 40% THINNER
- 60% LIGHTER IN WEIGHT



COMPACT

2 **MORE POWER**

TP-CW 18/350-C Li BL vs. IMPAXXO 18/230

- 52% HIGER TORQUE



3 **MORE FEATURES**

ANTI-KICKBACK: STATUS INDICATOR

- GREEN LIGHT:
ANTI-KICKBACK PROTECTION IS ACTIVE
- GREEN LIGHT (FLASHING):
KICKBACK TRIGGERED BY RAPID MOVEMENT
- NO LIGHT:
ANTI-KICKBACK IS OFF - MANUALLY DISABLED

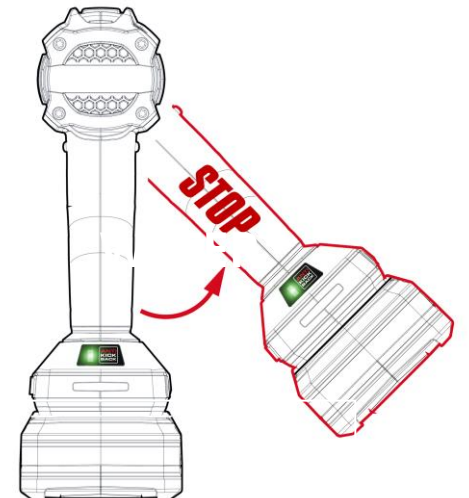

BRANDS – DETAILS

In million EUR	2023		2024		2025	
	Sales	TO Share	Sales	TO Share	Sales	TO Share
	613,8	64,0%	700.9	63,1%	712.1	61,6%
	70.1	7,3%	97.1	8,7%	132.8	11,5%
	131.6	13,7%	150.7	13,6%	160.0	13,8%



3. OUR WAY TO THE 2ND BILLION

EINHELL ACCESSORY



3. OUR WAY TO THE 2ND BILLION

Einhell Accessory

Sales Share 2025

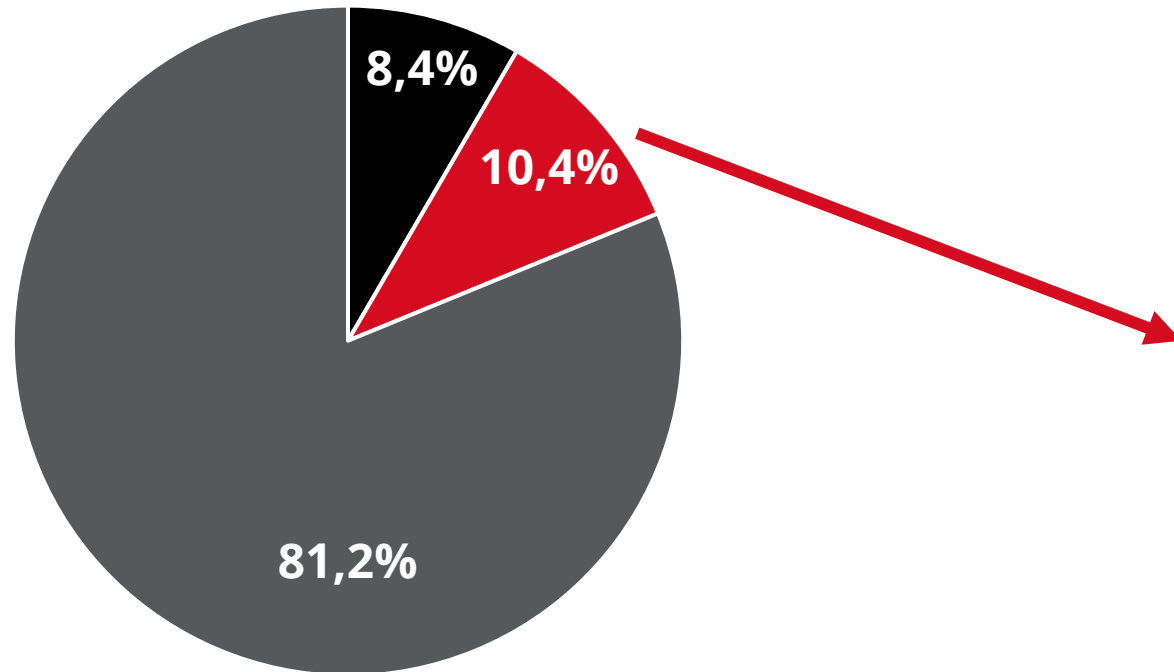

Machines

PXC Batteries & Chargers

Einhell Accessory

Einhell Accessory

Machine Accessory

Storage

Hand Tools



3. OUR WAY TO THE 2ND BILLION

Einhell Accessory – Machine Accessory



3. OUR WAY TO THE 2ND BILLION

Einhell Accessory – Storage

E-CASE-SYSTEM



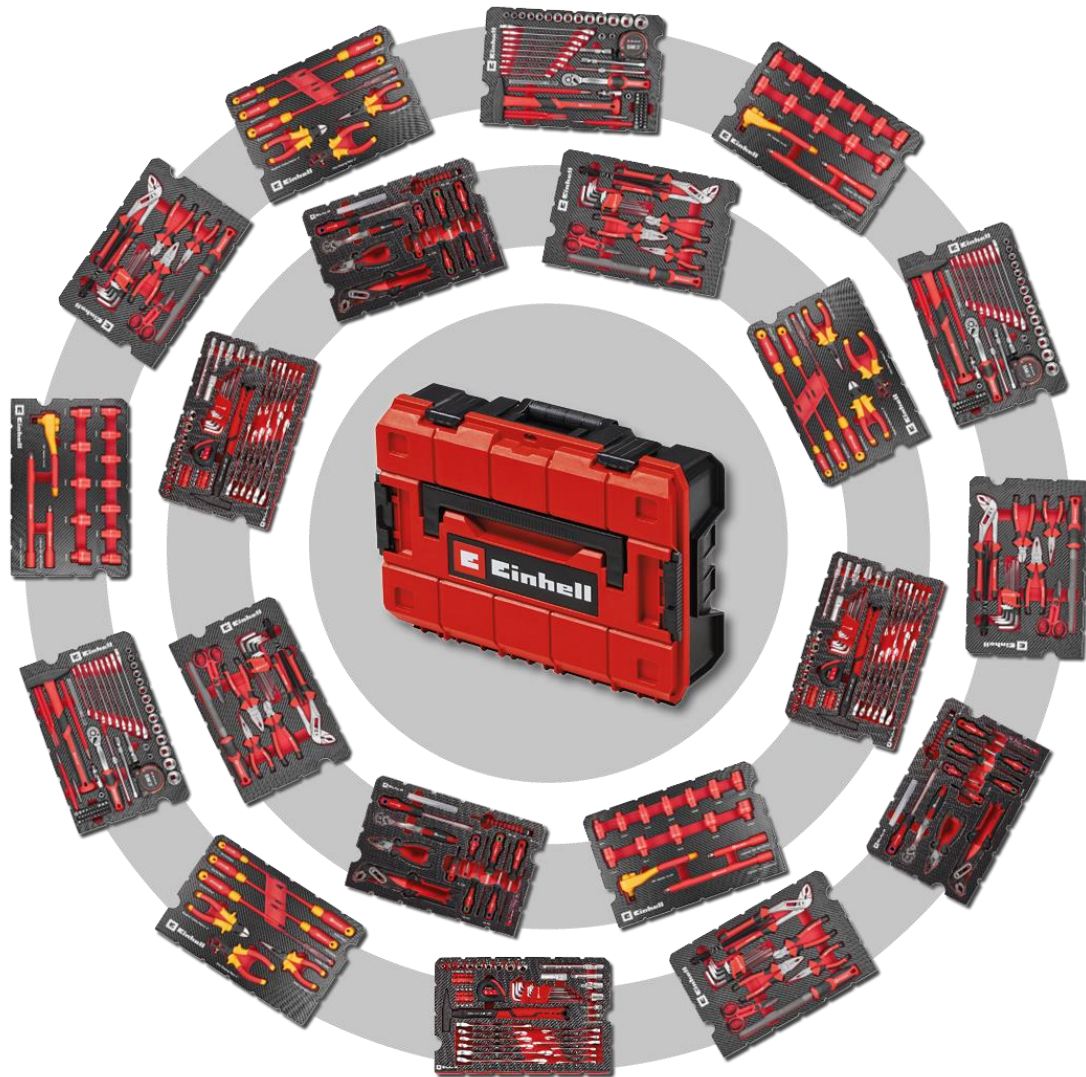

3. OUR WAY TO THE 2ND BILLION

Einhell Accessory – Hand Tools / Mix & Match



BRANDS – DETAILS

In million EUR	2023		2024		2025	
	Sales	TO Share	Sales	TO Share	Sales	TO Share
 Einhell	613.8	64,0%	700.9	63,1%	712.1	61,6%
 Einhell PROFESSIONAL	70.1	7,3%	97.1	8,7%	132.8	11,5%
 Einhell ACCESSORIES	131.6	13,7%	150.7	13,6%	160.0	13,8%
Einhell Accessory	20.7	2,2%	24.7	2,2%	29.1	2,5%
PXC batteries & chargers	60.4	6,3%	77.2	7,0%	79.5	6,9%
Einhell Accessory (kwb)	0,8	0,1%	3.4	0,3%	9.3	0,8%
kwb	49.7	5,2%	45.4	4,1%	42.1	3,6%



3. OUR WAY TO THE 2ND BILLION

DISTRIBUTION EXPANSION



3. OUR WAY TO THE 2ND BILLION

Turnover Potentials & Targets

» We will have our own sales subsidiaries in every relevant DIY market until 2030.

» Target markets for own subsidiaries / partners for 2026+:



USA



Mexico



Saudi-Arabia



UAE



Egypt



India

Turnover 2025

1.158 mio. €



Organic Growth

> 600 mio. €



Inorganic Growth

> 250 mio. €

» 2.000 mio. €



3. OUR WAY TO THE 2ND BILLION

Main National Markets – by DIY Turnover

2024 main DIY market sizes (in EUR bn)

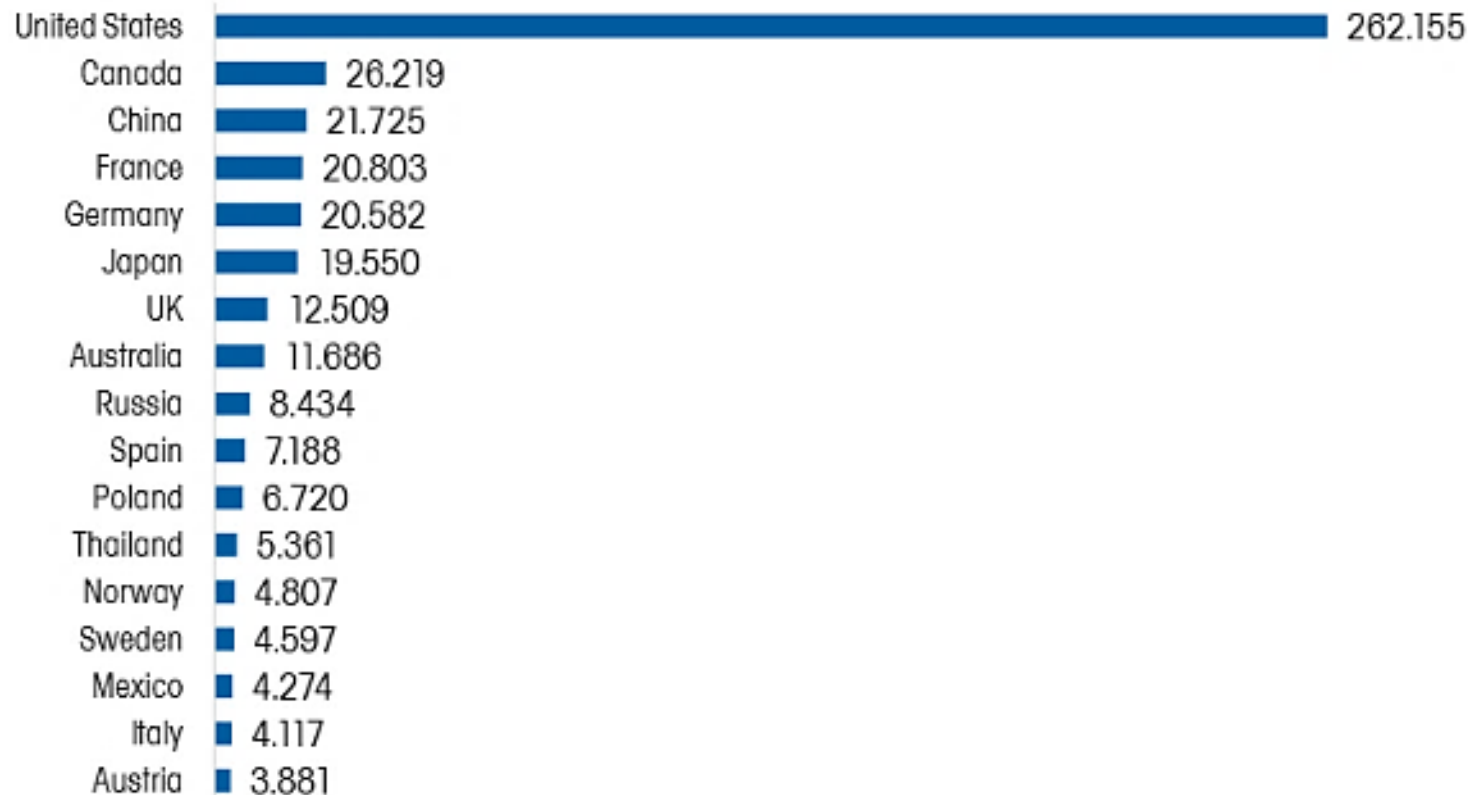

IN SHORT

USA

53% of global market

Top 5 countries

71% of global market

Top 10 countries

82% of global market

3. OUR WAY TO THE 2ND BILLION BRAND BUILDING



3. OUR WAY TO THE 2ND BILLION

Brand Strategy



Brand Positioning

Significant expansion of our positioning as „Cordless Excellence“ internationally (positioning in dominance area)



Price positioning

„Brand quality at the best price“ as clear price positioning for Einhell and Einhell PROFESSIONAL



Target Groups

- Private house & garden owner → Einhell
- White van man / craftsman → Einhell PROFESSIONAL



Brand differentiator next to „Cordless Excellence“:

We offer our customers & end consumers the best service experience in our industry.
“We turn our customers into Einhell fans!”

3. OUR WAY TO THE 2ND BILLION

Power Lifestyle Brand – From Power Tools to Power Lifestyle

Einhell is no longer just DIY and garden tools - we are evolving into a power lifestyle brand that gives cordless excellence in the following competence areas ...



GARDEN
TOOLS
PUMPS
CLEANING
RECREATION

FOR OUR
TARGET GROUPS ...



3. OUR WAY TO THE 2ND BILLION

Power Lifestyle Brand – Target Groups

... the private households & garden owners

DIY



Handcraft



Lawn Care



Watering



Car
Maintenance



Cleaning



Tree, Shrub &
Hedge Care



Recreation
& Camping

3. OUR WAY TO THE 2ND BILLION

Power Lifestyle Brand – Target Groups

... and for professionals / white van men

Remodeler



Floor Installer



Electrician



PV Installer



Landscaper



Facility Manager



Carpenter



Painter



Smart Home Tech



Gardener



Farmer



Car Mechanic



3. OUR WAY TO THE 2ND BILLION

Brand Partnerships with Mercedes F1 Team & FC Bayern

» As a **positioning accelerator**, we have **two brand cooperations** which help us, (1) to **position our brand faster** to where we want to be, and (2) to **build up our brand image**.



**MAXIMUM PERFORMANCE
TECHNOLOGY
POWER
ENDURANCE**

GLOBAL FOCUS



**COMPETENCE
DOMINANCE
SUCCESS
PASSION**

D/A/CH FOCUS



WATER + DUST
RESIST

Einhell PXC 4.0Ah SEALED



OFFICIAL
TOOL EXPERT



AMG
PETRONAS
FORMULA 1 TEAM

3. OUR WAY TO THE 2ND BILLION

Brand Partnerships with Mercedes-AMG Petronas F1 Team

» Visibility in Formula 1



On F1 car

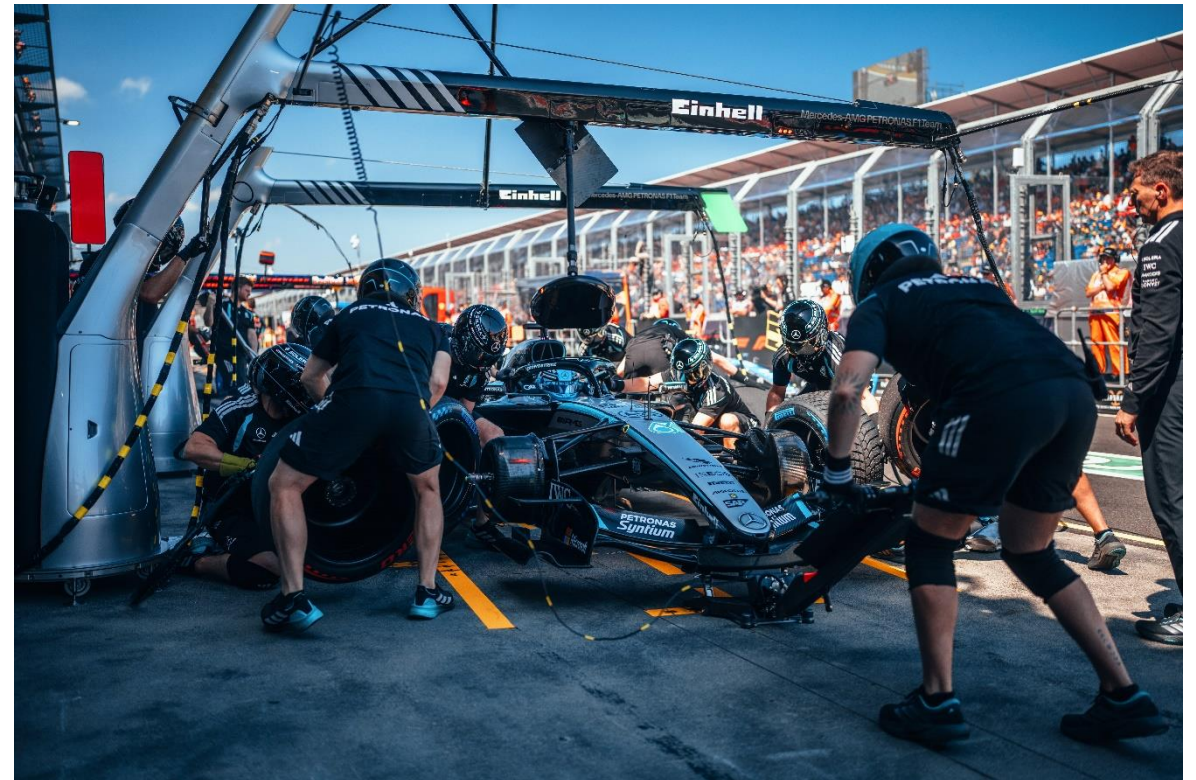

On „boom“

3. OUR WAY TO THE 2ND BILLION

Brand Partnerships with Mercedes-AMG Petronas F1 Team

» Visibility in Formula 1



Tools in usage



Tools in usage



E Einhell

Official Home & Garden Expert

4. EINHELL SHARE



4. EINHELL SHARE

Development & Key Share Data

SHARE PRICE DEVELOPMENT UNTIL 2026 IN EUR

„Long-term sustainable increase in value“

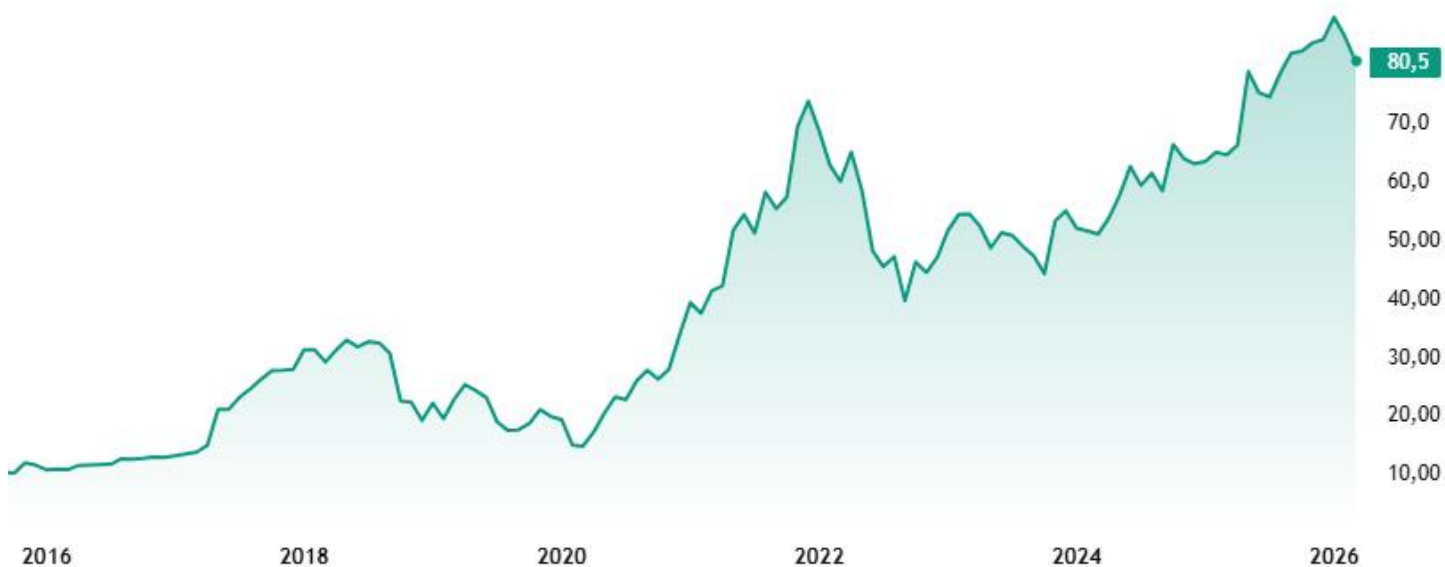

KEY SHARE DATA

SHARES OUTSTANDING	Total Premium (noted) Common	11,323,200 5,040,000 6,283,200
LAST CLOSING PRICE	EUR 75.20 (17.04.2026)	
MARKET CAPITALIZATION	EUR 851,5 m	
WKN	A40ESU	
ISIN	DE000A40ESU1	
LISTING	Frankfurt Stock Exchange – Prime Standard	
STOCK MARKET SEGMENT	SDAX	
DESIGNATED SPONSOR	ICF BANK AG	

4. EINHELL SHARE

Index Inclusion & Shareholding Structure

SHAREHOLDERS

„Stable shareholder structure thanks to the founding family as common shareholders “

Research Studies by: M.M. Warburg & Co., Hauck & Aufhäuser, Berenberg

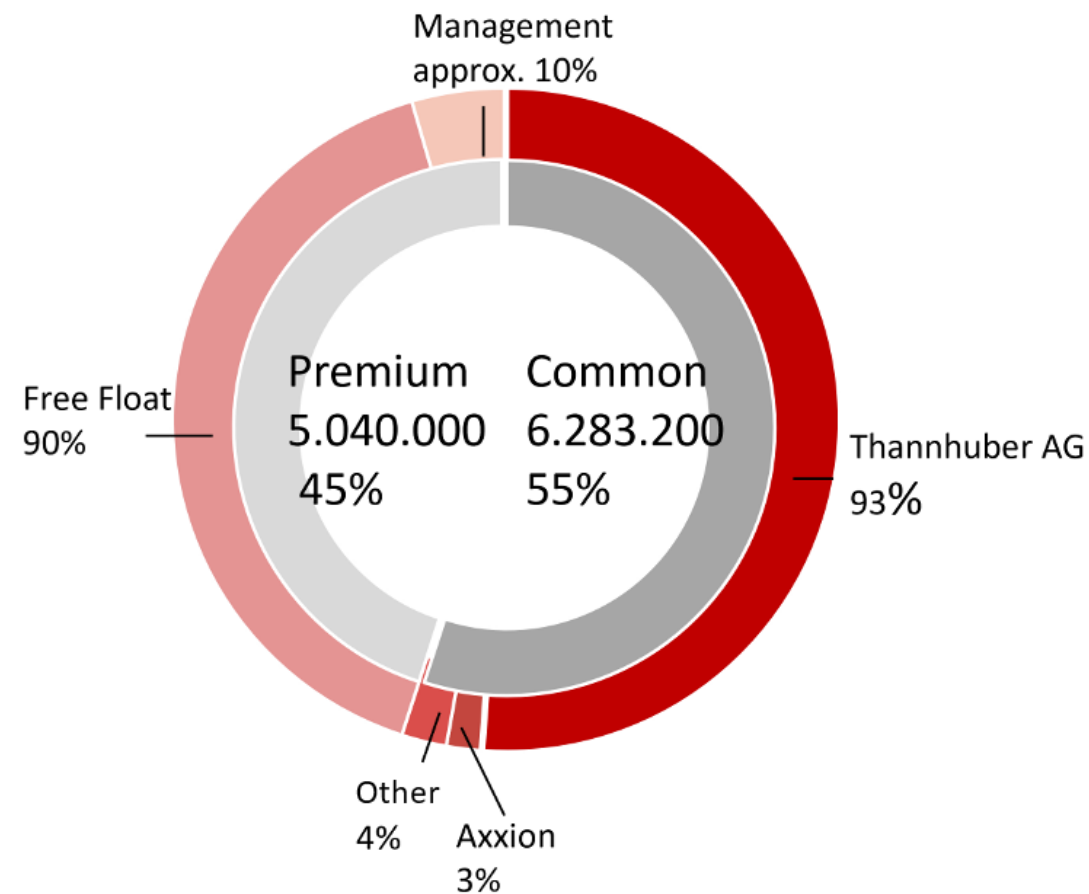

4. EINHELL SHARE

Sustainable and Growing Dividends

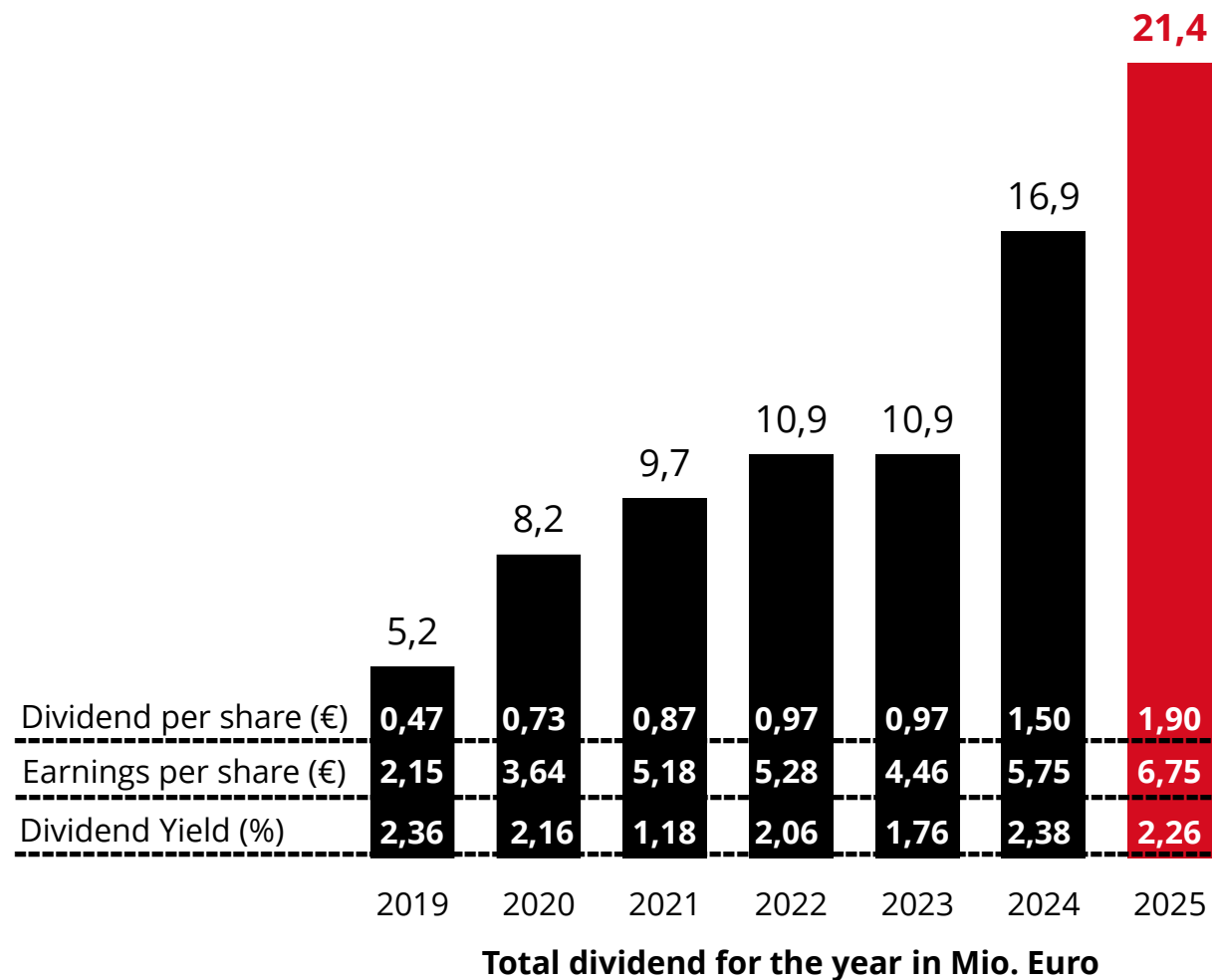

Dividend - History

The following dividends were paid for the respective financial years:

In EUR	Total	Common Shares	Premium Shares
2016	2.893.856	0,25	0,27
2017	4.403.616	0,38	0,40
2018	5.158.496	0,45	0,47
2019	5.158.496	0,45	0,47
2020	8.178.016	0,71	0,73
2021	9.687.776	0,85	0,87
2022	10.820.096	0,95	0,97
2023	10.820.096	0,95	0,97
2024	16.859.136	1,48	1,50
2025	21.388.416	1,88	1,90

5. SUMMARY



DISCLAIMER

This presentation contains forward-looking statements.

Forward-looking statements are based on specific assumptions and expectations at the time of this presentation.

They are therefore subject to risks and uncertainties, and actual results may differ considerably from the results in such forward-looking statements.

Various risks and uncertainties are determined by factors that do not lie in the EINHELL Group's sphere of influence and can therefore not be estimated with certainty at present.

This includes, without limitation, future market conditions and the economic trends as well as legal and political decisions.

Unless otherwise stipulated, all amounts are stated in thousands of euros (KEUR).

There may be minor deviations in this report and in other reports due to rounding of totals and the calculation of percentage figures.